

MITON®

CUCINE

**KITCHEN**

COLLECTION **2023**



Le groupe Cubo Design aime les défis et propose une nouvelle collection pleine de nouveautés et de détails d'une importance considérable. Le leitmotiv est le concept d'ouverture, considéré comme une invasion dans d'autres univers outre que la cuisine, qui génère des espaces infinis en le privant de ses vraies frontières. UNE plateforme riche avec plus de 350 finitions de façades, 120 pour les plans de travail, qui garantit une offre capable de satisfaire les différentes exigences esthétiques et fonctionnelles du marché. Une excellence italienne transmise depuis des générations tournées vers l'avenir. Au début des années 60 Giuseppe Arangiario commence l'aventure : il se rend vite compte que le Made in Italy est une garantie de succès et l'exportation de ses créations commence ; en quelques années il en devient un des grands exportateurs de cuisines modulaires au point d'inciter une multinationale américaine à croire en lui. Bien sûr, les temps changent, les matériaux, la demande, le design et les goûts aussi. En revanche, le besoin de qualité (intérêt primordial alors comme aujourd'hui) ne change pas. Et aujourd'hui il y a Antonio, fils de Giuseppe, qui gère l'entreprise avec la même prévoyance, conscient que la qualité, la créativité et la fiabilité des produits italiens offrent toujours des garanties dans tout le monde. Et l'aventure continue, avec l'ouverture d'un nouveau centre de production qui intègre les processus de l'industrie 4.0, la Smart Factory, l'efficacité énergétique et l'approche écologique. Le résultat de cette vision est un centre de production futuriste, dans lequel le processus de production a été repensé grâce à l'automatisation numérique, en vue d'une efficacité maximale. L'énergie qui fait avancer les entreprises et les personnes est produite de manière indépendante et réutilisée dans un cercle vertueux. Tout est conçu dans le respect de la planète. Tous les efforts sont faits pour offrir un meilleur présent aux générations futures.

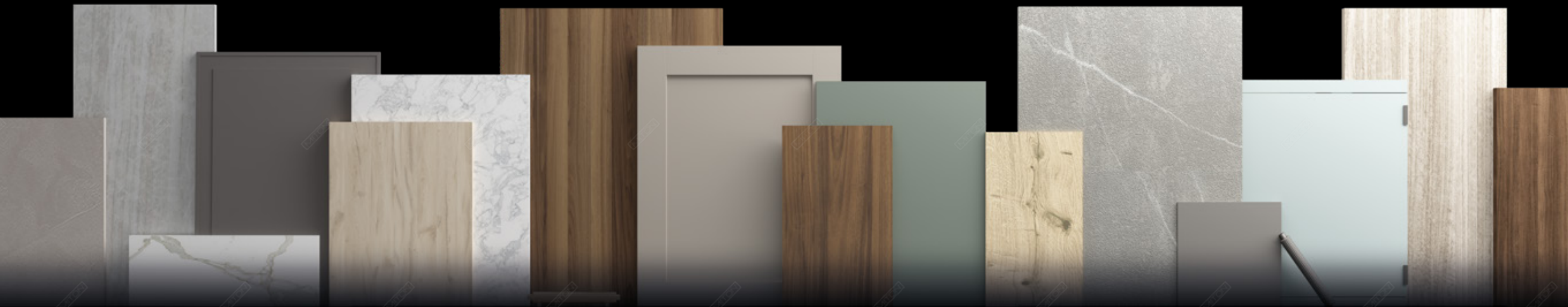



# COLLECTION

<b>MÉNTA</b>	<i>8</i>
<b>ANUBA</b>	<i>90</i>
<b>MÉDEA</b>	<i>102</i>
<b>NEW MASA</b>	<i>116</i>
<b>TALÌA</b>	<i>142</i>



# MÉNTA

GRIGIO EMME / EUCALIPTO FUMO











*Un espace à vivre qui  
allie esthétique et fonctionnalité.*









Les buffets sont en bois bilaminé Eucalipto Fumo. Les colonnes reprennent les mêmes matériaux également dans le système Waind, en combinaison avec le bilaminé mat Grigio Emme des modules adjacents.







L'îlot est en bilaminé Grigio Emme mat avec ouverture à travers la gorge nero traffico, le plan de travail est en grès pietra piacentina grigio fiammato. La bibliothèque et le plan sandwich sont en bilaminé bois Eucalipto fumo.







# MÉNTA

BETON GIOVE / NERO ONICE OPACO / ROVERE SCANDY











L'îlot est en Bilaminé cemento beton Giove avec les meubles bas au centre avec tiroirs en vue avec façades en bilaminé bois rovere Scandy comme le plan snack, soutenu par un pied Industrial en métal noir mat. Le plan de travail est en grès Fokos Sale mat.

*Un environnement esthétique moderne et raffiné.*



A droite, les colonnes sont Ménta PET laser nero onice et la niche ouverte est en bilaminé bois rovere Scandy.











Détail de la poignée IRON en aluminium nero traffico.  
A droite, l'îlot en bilaminé cemento Beton Giove avec  
poignée Jay nero opaco.





Crédence avec vitrine Petra avec structure et étagères en bilaminé bois rovere Scandy et verre extra-clair. Portes supérieures et inférieures en PET Laser nero onice opaco.









# MÉNTA

BIANCO NORDICO OPACO / ROVERE CHIARO

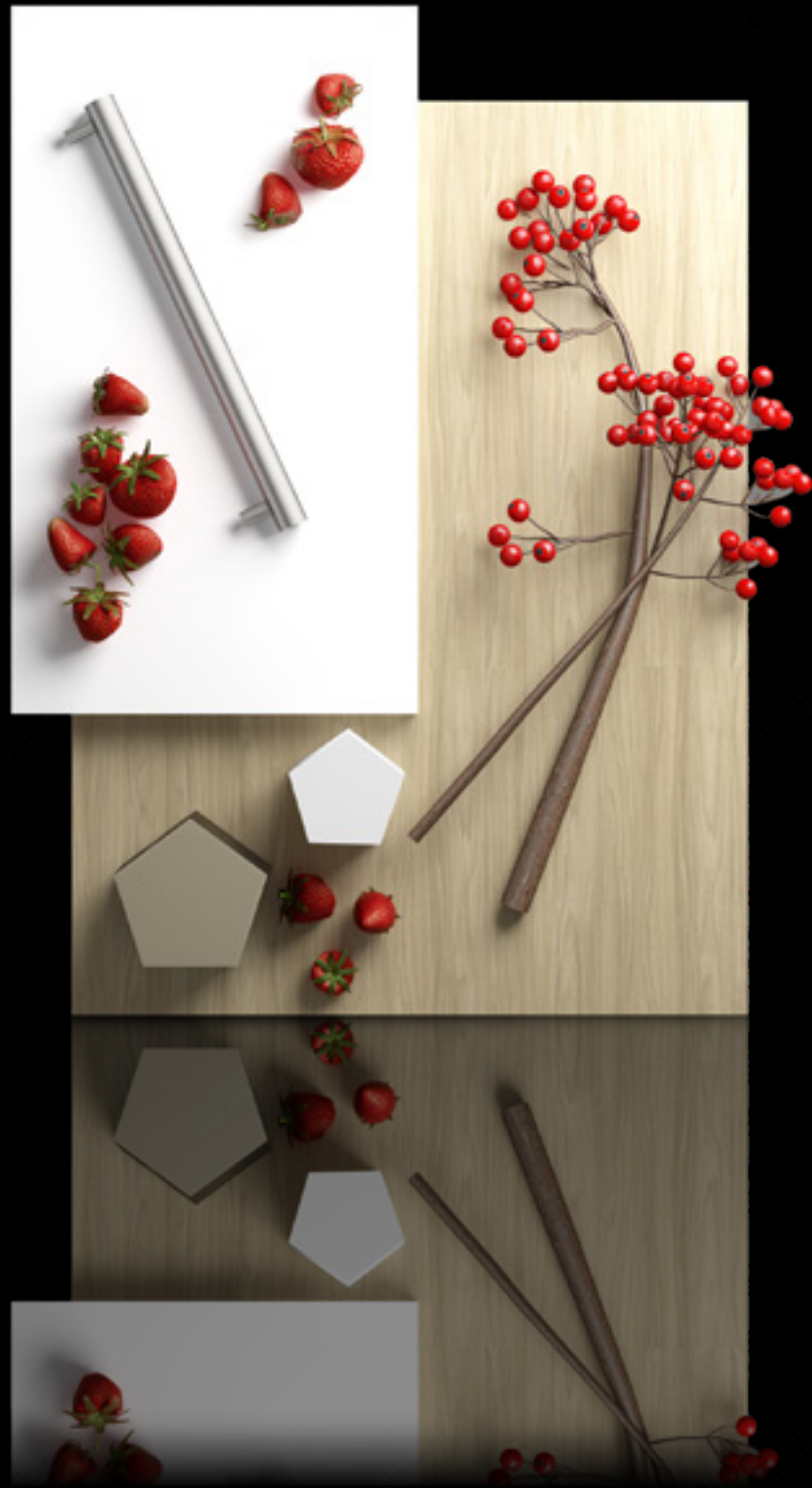









Les colonnes sont en PET bianco nordico opaco, les étagères et les crédences sont en bilaminé bois rovere chiaro.

*Les lignes essentielles racontent une parfaite harmonie des matières.*









L'îlot est en PET laser bianco nordico avec poignée JAY aluminium champagne sur le côté opérationnel.  
Le plan de travail est en grès Solid White opaco.









# MÉNTA

NOCE ADIGE / CRETA OPACO











*L'îlot est le coeur de la  
convivialité et du partage.*









L'îlot est en PET Laser Creta opaco avec ouverture avec gorge nero traffico. Les colonnes et les niches ouvertes Waind sont en bilaminé bois Noce Adige.







## ESPACES INFINIS

Les buffets Miri sont en bilaminé bois Noce Adige avec Poignée Linear noir mat. Le coin salon reprend les mêmes matériaux que la cuisine et permet l'insertion des vitrines Bellevue verre fumé et des niches ouvertes Waind\_K hauteur 138cm.







# MÉNTA

NOCE CORDESCO / VERDE POLVERE OPACO

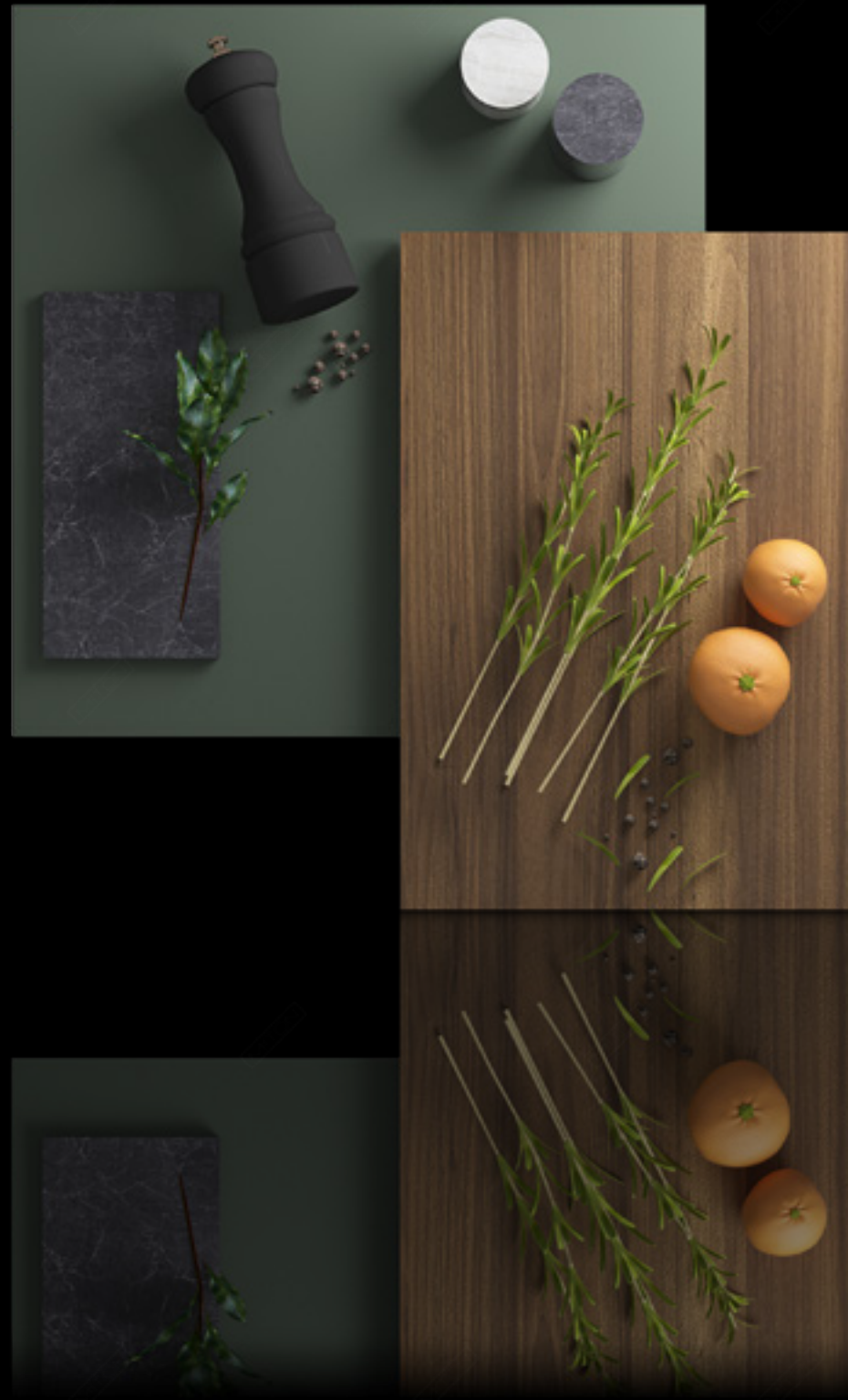









L'îlot est en bilaminé bois noce Cordesco, le plan de travail est en Grès Nero Greco ép. 1,2cm.

*Dualismes chromatiques exclusifs  
protagonistes de la cuisine.*









## LES MULTIPLES ESSENCES DE MÉNTA

Les colonnes sont en PET Laser Verde polvere opaco, les niches ouvertes Waind sont en bilaminé bois noce Cordesco.









# MÉNTA

GRIGIO MEDIO OPACO / GRIGIO ARDESIA OPACO / NOCE NATURALE









*Contaminations de matériaux qui  
se fondent dans un espace rationnel*









La péninsule est en laque mat Grigio Antracite et le plan de travail est en Grès Marble Grey ép. 1,2 cm. Les buffets sont en Bilaminé bois Noce naturelle avec crédence en Bilaminé bois Noce naturelle.







Les colonnes sont en bilaminé opaco grigio medio et les niches ouvertes Waind sont en bilaminé bois Noce naturelle.









# ANUBA

PAXOS GREY OPACO









Les colonnes conçues comme des portails sont en laque mat Paxos Grey avec inserts et poignées Ride-M / XL canna di fucile.







*Le charme irrésistible des  
Ambiances méditerranéennes.*

L'îlot est en laque mat Paxos Grey avec des inserts et des poignées Ride-XL canna di fucile.  
Le plan de travail de grande épaisseur est en grès Statuarietto opaco, à côté un plan en Grès  
ép. 1,2 cm de la même finition et un plan snack de grande épaisseur en placage bois Rovere  
Naturale Nodato.









Détail de la poignée Ride-M / XL canna di fucile.





# MÉDEA

VISONE OPACO / BIANCO LUNA OPACO / NOCE ADIGE









*Un entrelacement équilibré  
entre mémoire et innovation.*











Les meubles bas et les meubles hauts au mur sont en Bilaminé Visone 22 mm opaco avec poignée « Manor » en finition cuivre. La boiserie frame est composée de cloisons en aluminium anodisé cuivre, de dos en bilaminé Visone opaco et d'étagères avec led en bilaminé bois Noce Adige. Plan de travail en grès Arabescato opaco ép. 12 mm.







L'îlot et les colonnes sont en Bilaminé mat de 22 mm Bianco Luna avec poignée « Manor » finition cuivre, le plan snack est en Bilaminé bois Noce Adige. Les niches ouvertes Frame placées aux extrémités de l'îlot sont en aluminium anodisé cuivre avec étagères en verre fumé.







# NEW MASA

CARRUBA OPACO











L'îlot, les colonnes et les meubles bas au mur sont en laque Carruba opaco avec poignée Rem S et Rem L finition canna di fucile. Le plan de travail est en grès Diamond Cream opaco ép. 4cm.  
En haut un détail de la poignée Rem L en finition canna di fucile.









La crédence se compose de vitrines avec structure en bilaminé bois Noce Adige et porte en verre Petra. Les meubles bas sont en laque Carruba opaco avec poignée Rem S et Rem L canna di fucile.

*Inspirations contemporaines pour un environnement authentique.*





L'îlot est en laque Carruba opaco avec poignée Rem S en finition canna di fucile. Le plan de travail et le monobloc sont en Grès Diamond Cream opaco ép. 4 cm. Le plan snack est en bilaminé bois Noce Adige ép. 4cm.





# NEW MASA

GRIGIO BOX OPACO / NOCE MONZA











*Suggestions inédites entre  
parfums et chaleur domestique.*









La péninsule est New Masa en laque Grigio Box opaco avec ouverture avec gorge nero traffico, le plan de travail est en grès Calacatta Michelangelo opaco.







Les colonnes sont Ménta Bilaminé bois Noce Monza et niche ouverte en PET laser nero onice de 12 mm.







# TALIA

GRIGIO ANTRACITE OPACO / COTONE OPACO / NOCE AMERICANO

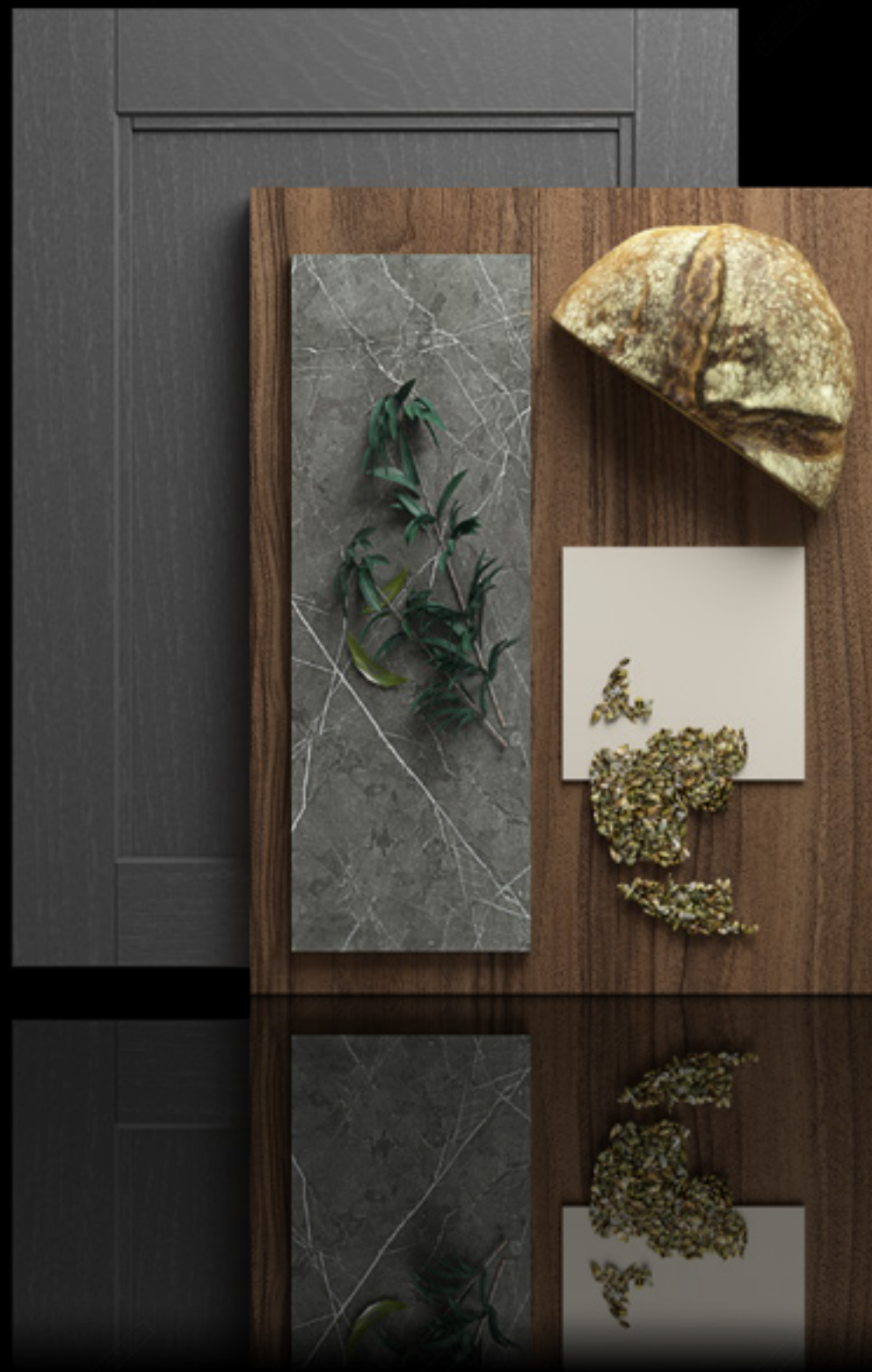









*Une âme traditionnelle habillée  
de rigueur architecturale.*









Les colonnes sont en laque pores ouverts Cotone opaco avec poignée Tube noir, les niches ouvertes Waind sont en bilaminé bois Noce Americano avec dos de série en nero Carbone et plan de travail en Grès Marble Grey opaco ép. 1,2cm.







La péninsule est en laque pores ouverts Grigio Antracite opaco avec gorge noir et le plan de travail est en grès ép. 1,2 cm Marble Grey opaco ép. 1,2 cm. Les meubles hauts sont en bilaminé bois Noce americano.





Détail de la bibliothèque Pivot composée de poteaux en aluminium nero opaco et d'étagères en laque nero traffico opaco.





# TECHNIQUES



# MÉNTA

GRIGIO EMME OPACO / EUCALIPTO FUMO

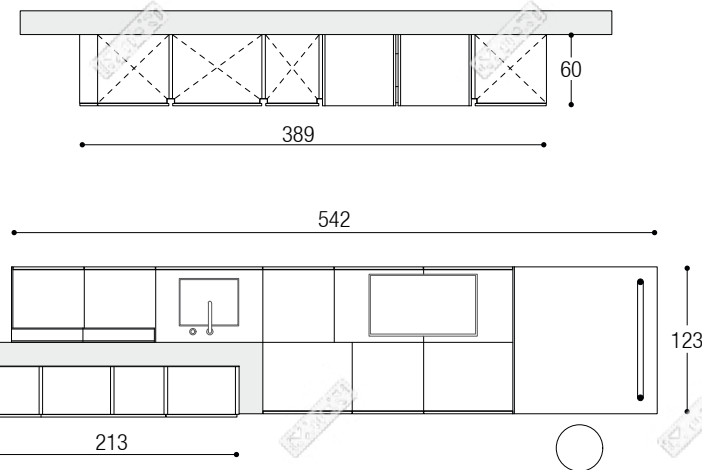
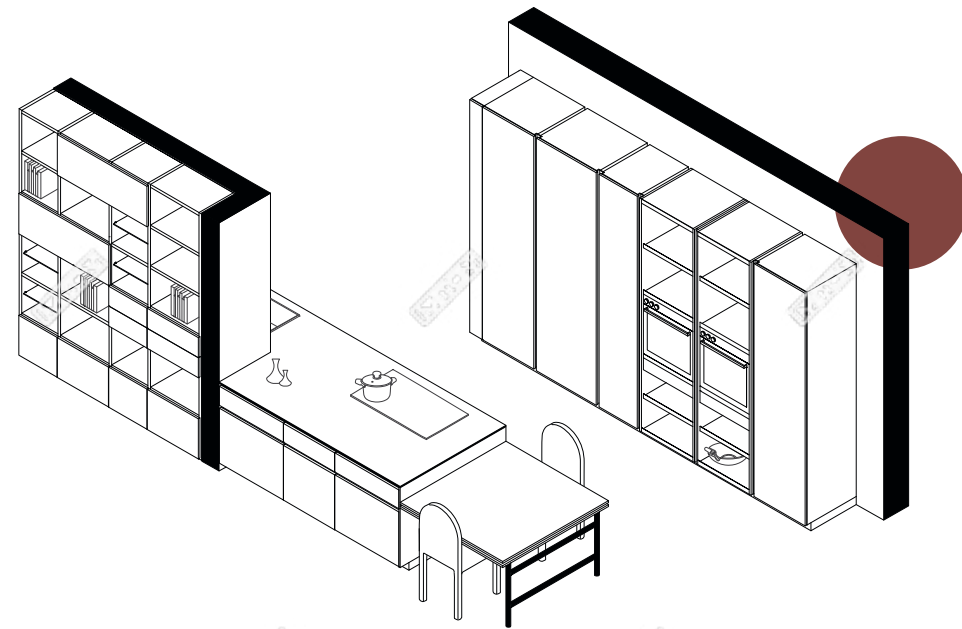

FACADE COLONNES\_ MÉNTA LAQUE BEIGE KENIA BRILLANT  
 FACADE COLONNE\_ MÉNTA BILAMINE' BOIS ROVERE TERRANERA  
 SYSTEME WAIND\_ STRUCTURE OUVERTE EN BILAMINE' BOIS ROVERE TERRANERA AVEC  
 DOS LAQUE' VERDE BOSCO OPACO ET ECLAIRAGE LED  
 FACADE ILOT\_ MÉNTA FENIX VERDE COMODORO  
 FACADE ILOT\_ MÉNTA LAMINATO PIETRA MAILAND PLAMKY  
 PLAN DE TRAVAIL\_ GRES PIETRA PIASENTINA GRIGIO FIAMMATO  
 LIBRAIRIE\_ LIBRAIRIE DOUBLE FACE EN BILAMINE' BOIS EUCALIPTO FUMO ET PORTES  
 EN BILAMINE' GRIGIO EMME MAT ET ÉCLAIRAGE À LED  
 TABLEAU\_ SANDWICH EN BILAMINE' BOIS EUCALIPTO FUMO  
 NEW GRID\_ DOS BILAMINE' BOIS EUCALIPTO FUMO AVEC MENSOLES IN PET LASER  
 NERO ONICE OPACO

# MÉNTA

BETON GIOVE / NERO ONICE OPACO / ROVERE  
 SCANDY

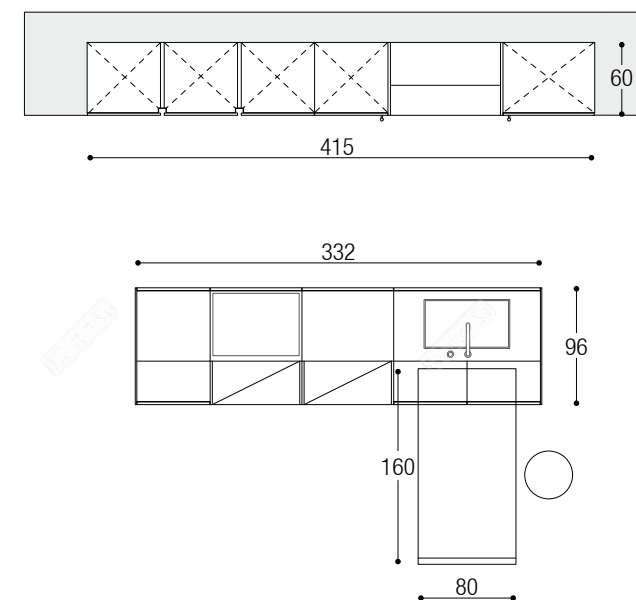
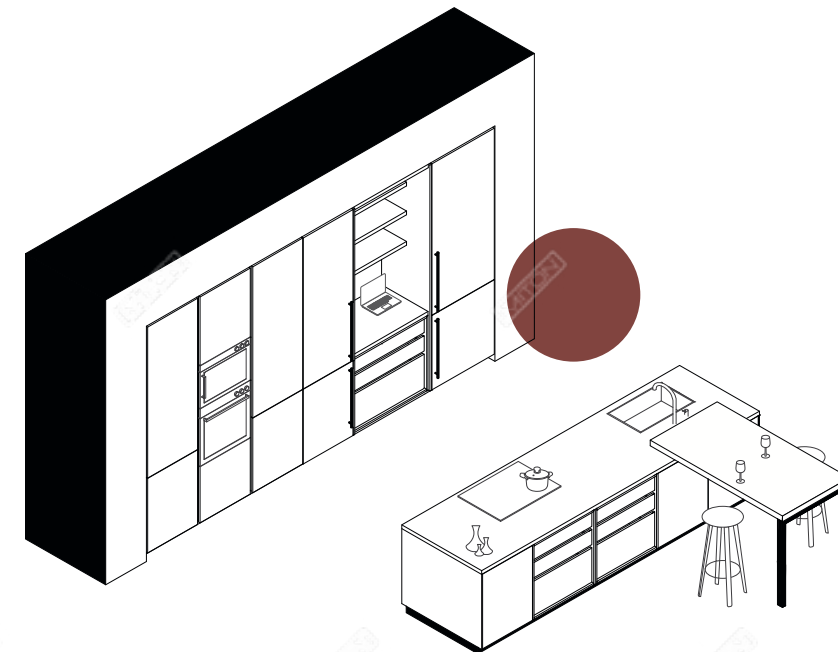

FACADE COLONNES\_ MÉNTA COMPOSEE PAR PANNEAU EN PET LASER NERO ONICE OPACO  
 HOME OFFICE\_ STRUCTURE OUVERTE EN BILAMINE' BOIS ROVERE SCANDY AVEC PLAN,  
 ETAGERES ET ECLAIRAGE LED  
 FACADE ISOLA\_ MÉNTA EN BILAMINE' CEMENTO BETON GIOVE  
 MEUBLES BAS EN VUE\_ FACADES EN BILAMINE' BOIS ROVERE SCANDY ET STRUCTURE EN  
 NERO CARBONE  
 PLAN SNACK\_ PLAN EN BILAMINE' BOIS ROVERE SCANDY PIED INDUSTRIAL NOIR  
 FACADE VITRINE\_ FACADE VERRE PETRA AVEC CADRE EN ALLUMINIUM NERO TRAFFICO ET  
 VERRE NOIR FUMÉ  
 PLAN DE TRAVAIL\_ EN GRES FOKOS SALE



# MÉNTA

BIANCO NORDICO OPACO / ROVERE CHIARO

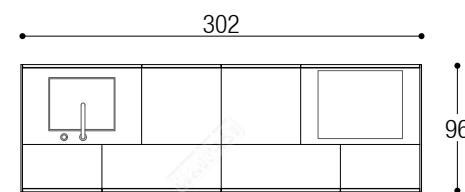
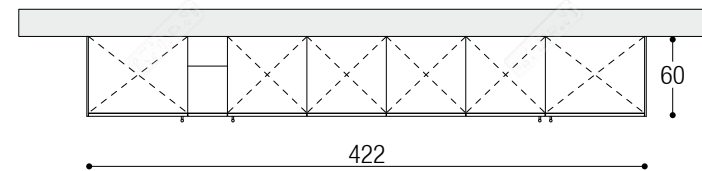
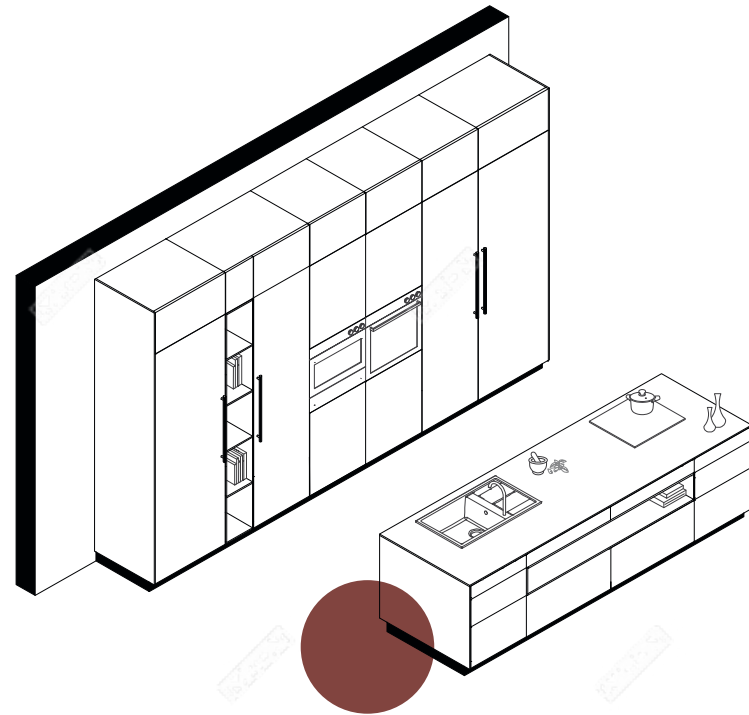

FACADE COLONNES\_ MÉNTA PET LASER BIANCO NORDICO OPACO  
 FACADE MEUBLES BAS\_ MÉNTA PET LASER BIANCO NORDICO OPACO  
 NICHE OUVERTE\_ BILAMINE' BOIS ROVERE CHIARO  
 PLAN DE TRAVAIL\_ GRES SOLID WHITE OPACO EP. 1,2 CM

# MÉNTA

NOCE ADIGE / CRETA OPACO

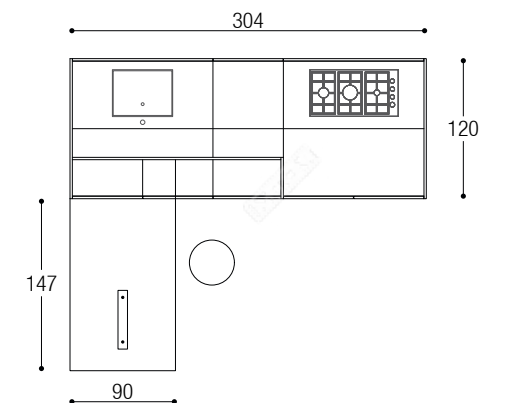
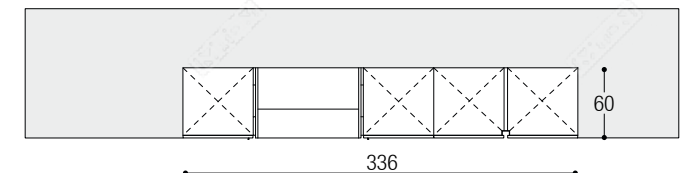
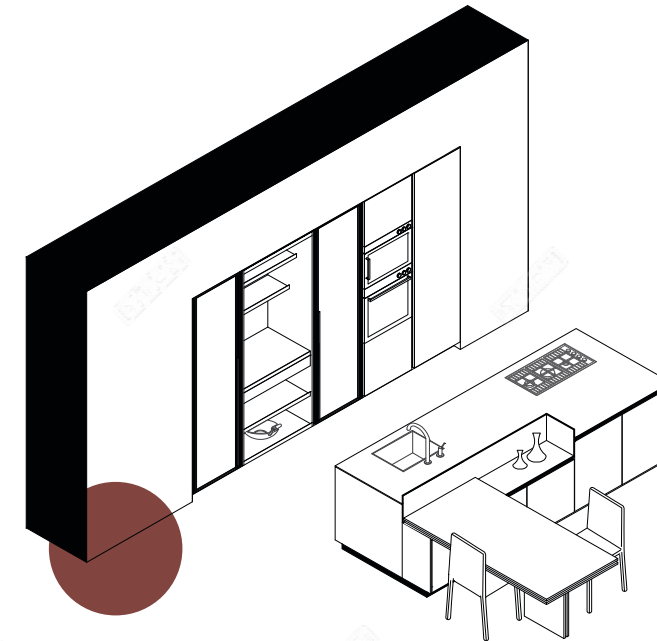

FACADE COLONNES\_ MÉNTA BILAMINE' BOIS NOCE ADIGE  
 SYSTEME WAIND\_ STRUCTURE OUVERTE EN BILAMINE' BOIS NOCE ADIGE ET  
 ECLAIRAGE LED  
 FACADE VITRINE\_ BELLEVUE AVEC CADRE EN ALLUMINIUM NERO OPACO, VERRE FUMÉ  
 ET POIGNEE LINEAR VERTICALE. STRUCTURE EN BILAMINE' BOIS NOCE ADIGE ET  
 ECLAIRAGE LED  
 FACADE ILOT\_ MÉNTA PET LASER CRETA OPACO  
 TABLE\_ BILAMINE' BOIS NOCE ADIGE  
 PLAN DE TRAVAIL ILOT\_ GRES LIMESTONE OPACO EP. 1,2 CM  
 GORGE\_ ELLE NERO TRAFFICO OPACO



# MÉNTA

NOCE CORDESCO / VERDE POLVERE OPACO

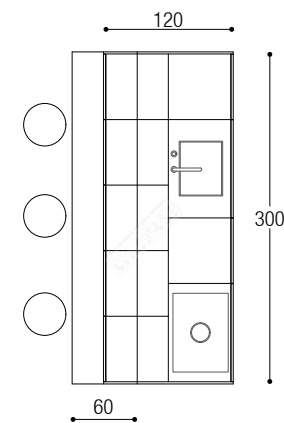
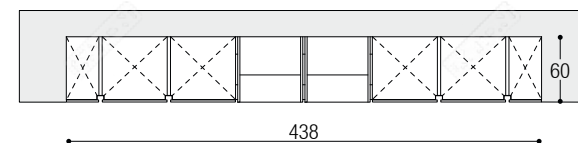
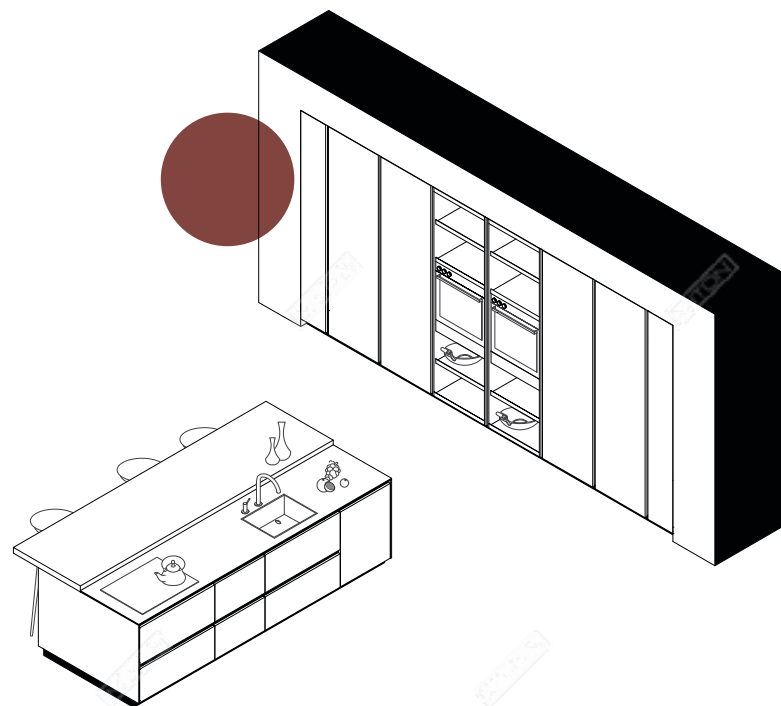

FACADE COLONNA\_ MÉNTA PET LASER VERDE POLVERE OPACO  
 SYSTEME WAIND\_ STRUCTURE OUVERTE EN BILAMINE' BOIS NOCE CORDESCO ET  
 ECLAIRAGE LED  
 FACADE ILOT\_ MÉNTA BILAMINE' BOIS NOCE CORDESCO  
 PLAN DE TRAVAIL\_ GRES NERO GRECO EP. 1,2 CM

# MÉNTA

GRIGIO ARDESIA OPACO / GRIGIO MEDIO OPACO /  
 NOCE NATURALE

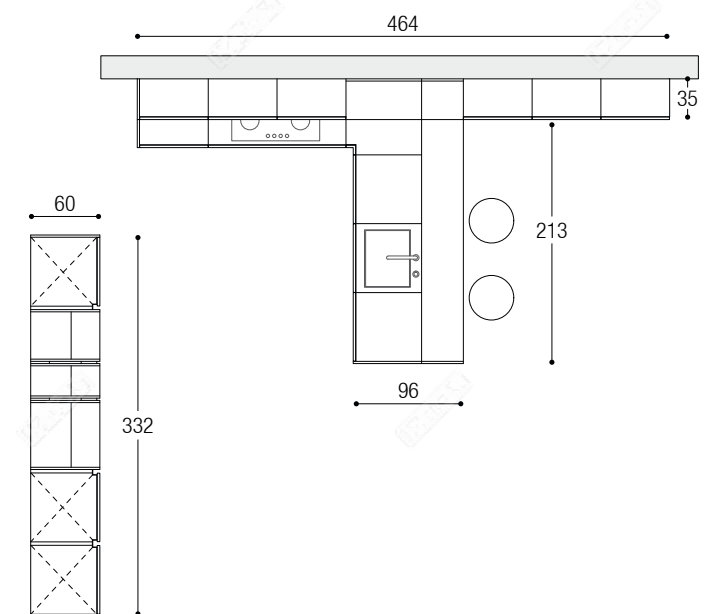
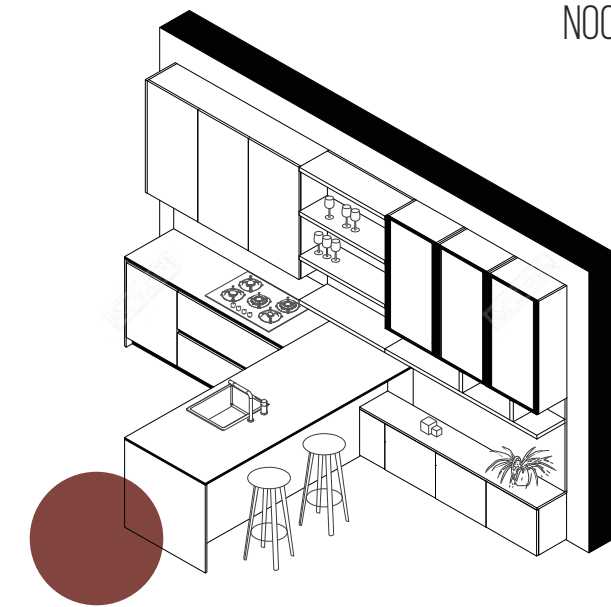
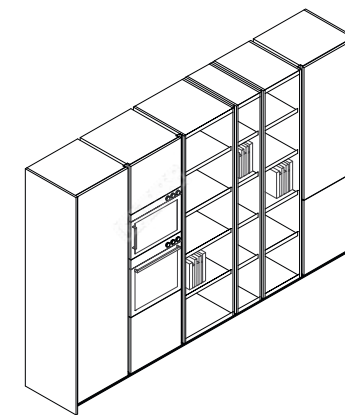

FACADE COLONNES\_ MÉNTA BILAMINE' OPACO GRIGIO MEDIO OPACO  
 FACADE MEUBLES BAS ET HAUTS\_ MÉNTA LAQUE GRIGIO ANTRACITE OPACO  
 FACADE VITRINE\_ BELLEVUE AVEC CADRE EN ALLUMINIUM NERO OPACO ET VERRE FUMÉ  
 STRUCTURE GRIGIO ANTRACITE OEA ET ECLAIRAGE LED  
 SYSTEME WAIND\_ STRUCTURE OUVERTE EN BILAMINE' BOIS NOCE NATURALE AVEC DOS  
 DE SERIE GREY FABRIC ET ECLAIRAGE LED  
 PLAN DE TRAVAIL\_ GRES MARBLE GREY OPACO EP. 1,2 CM



# ANUBA

PAXOS GREY

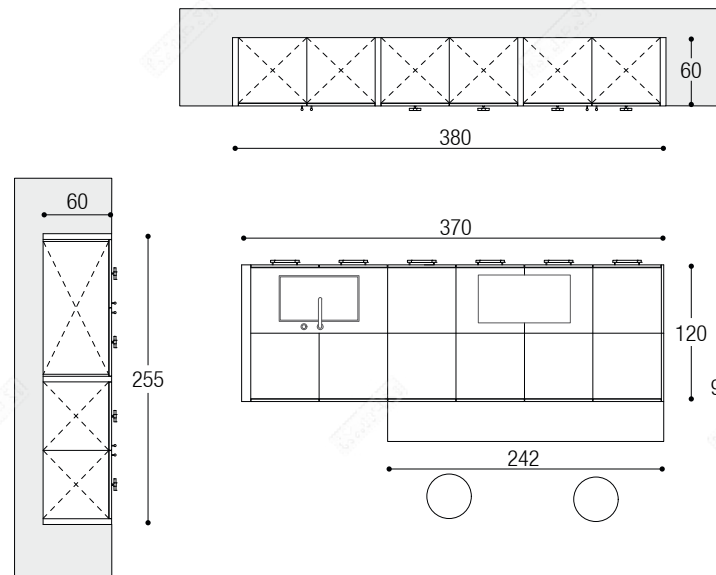
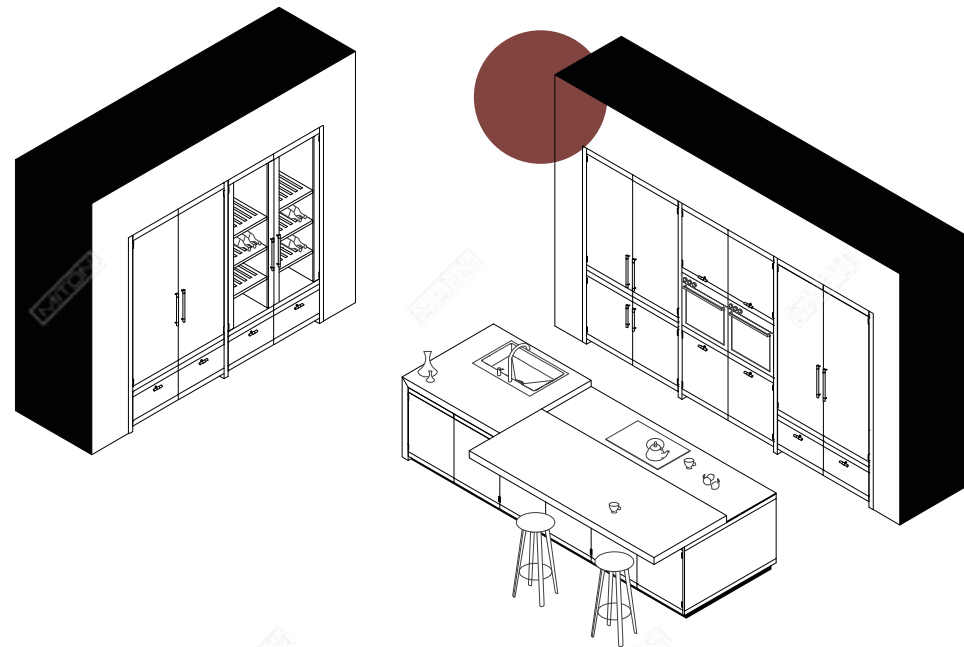

FACADE COLONNES ET ILOT\_ ANUBA LAQUE PAXOS GREY OPACO AVEC FRAISAGE,  
 INSERTS ET POIGNEES RIDE CANNA DI FUCILE  
 PLAN SNACK\_ PLACAGE BOIS ROVERE NAURALE NODATO  
 MONOBLOC EVIER\_ GRES STATUARIETTO OPACO EP. 8 CM  
 PLAN DE TRAVAIL\_ GRES STATUARIETTO OPACO EP. 1,2 CM

# MÉDEA

VISONE OPACO / BIANCO LUNA OPACO / NOCE  
 ADIGE

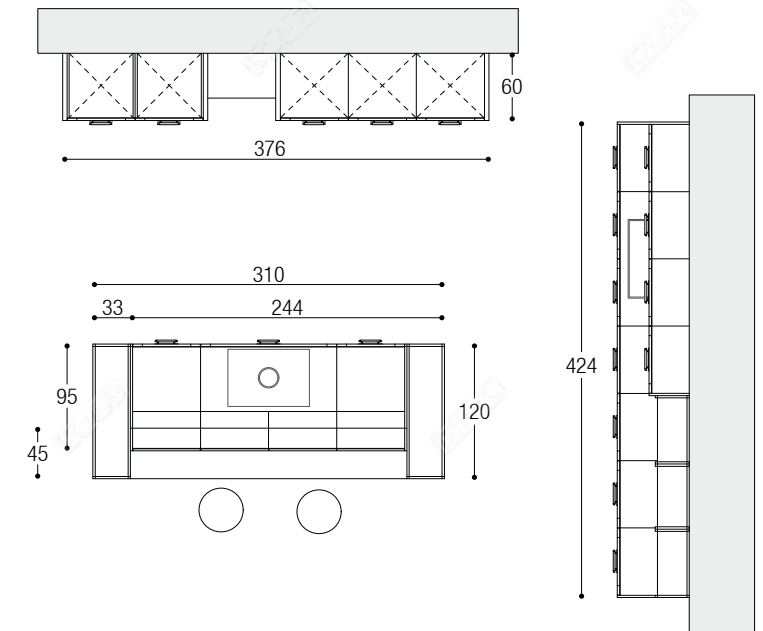
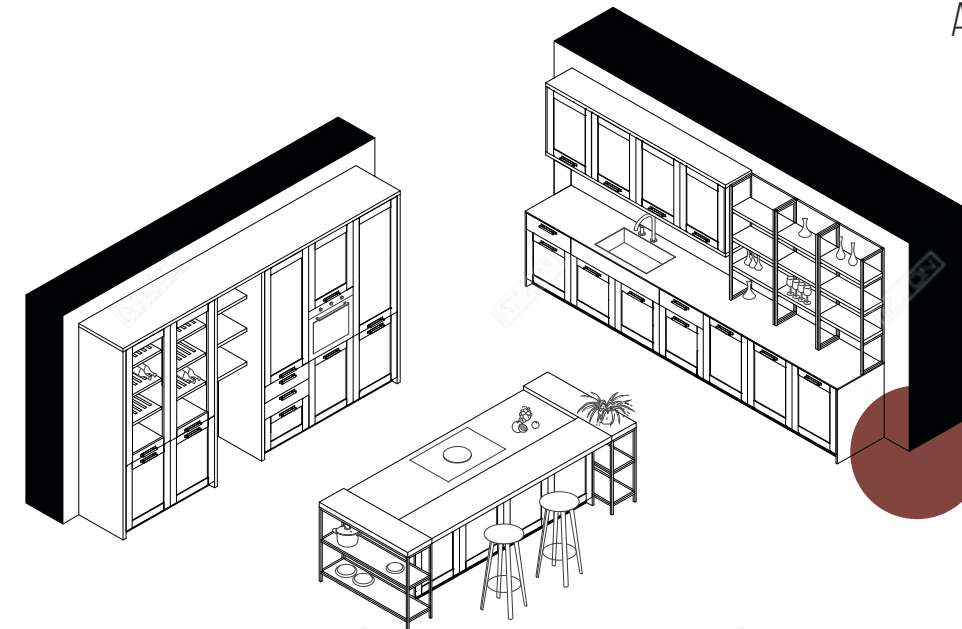

FACADE COLONNES ET MEUBLES BAS\_ MÉDEA BILAMINE' VISONE OPACO ET BIANCO  
 LUNA EP. 22 MM  
 BOISERIE\_ FRAME\_ ALLUMINIUM ANODISE' CUIVRE ET BILAMINE' BOIS NOCE ADIGE  
 FACADE ILOT\_ MÉDEA BILAMINE' BOIS NOCE ADIGE  
 BOISERIE FRAME\_ ALLUMINIUM ANODISE' CUIVRE AVEC ETAGERES EN VERRE FUMÉ  
 PLAN DE TRAVAIL\_ GRES ARABESCATO OPACO EP. 1,2 CM  
 POIGNEE\_ MANOR CUIVRE



# NEW MASA

CARRUBA OPACO

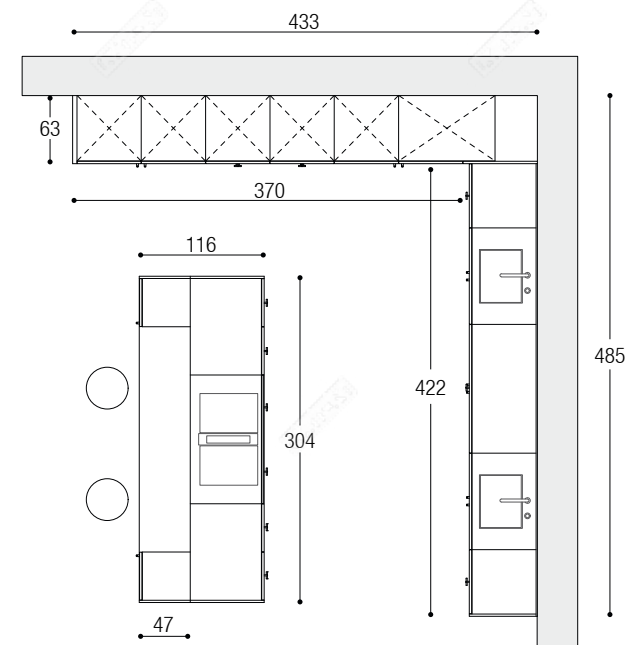
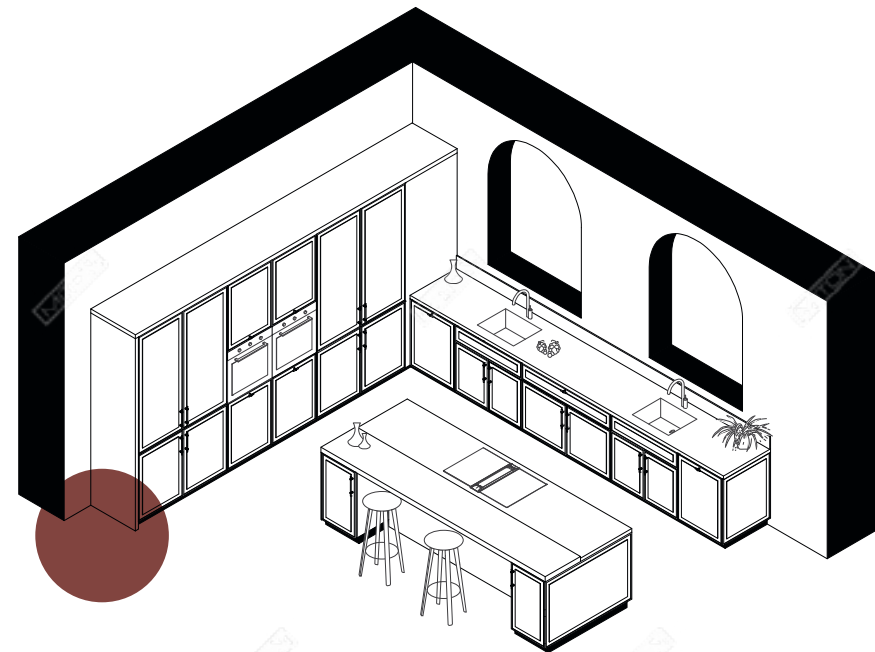

FACADE COLONNES, MEUBLES BAS\_ NEW MASA LAQUE CARRUBA OPACO AVEC  
 POIGNEE REM S ET REM M CANNA DI FUCILE  
 PLAN DE TRAVAIL\_ GRES YAMUNA OPACO  
 POIGNEE\_ REM S ET REM M CANNA DI FUCILE  
 VITRINES\_ STRUCTURE EN BILAMINE' BOIS NOCE ADIGE, VITRINE PETRA AVEC VERRE  
 EXTRACHIARO  
 PLAN SNACK\_ BILAMINE' BOIS NOCE ADIGE

# NEW MASA

GRIGIO BOX OPACO / NOCE MONZA

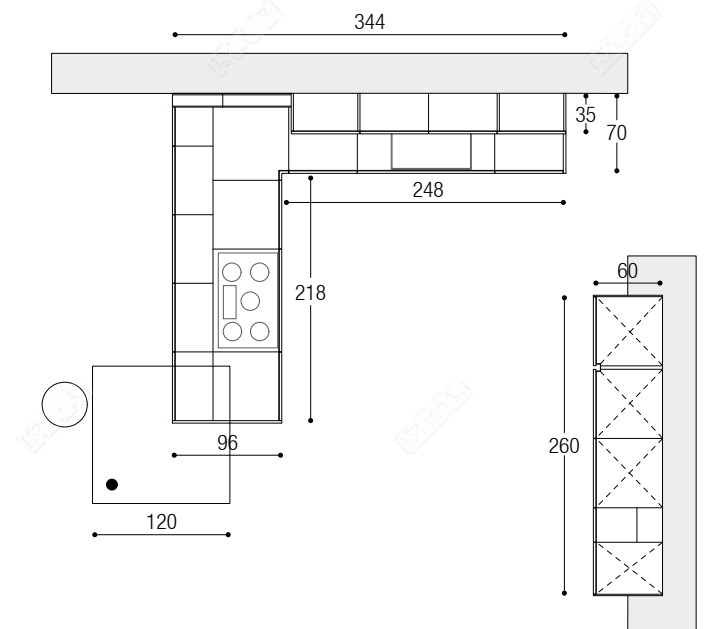
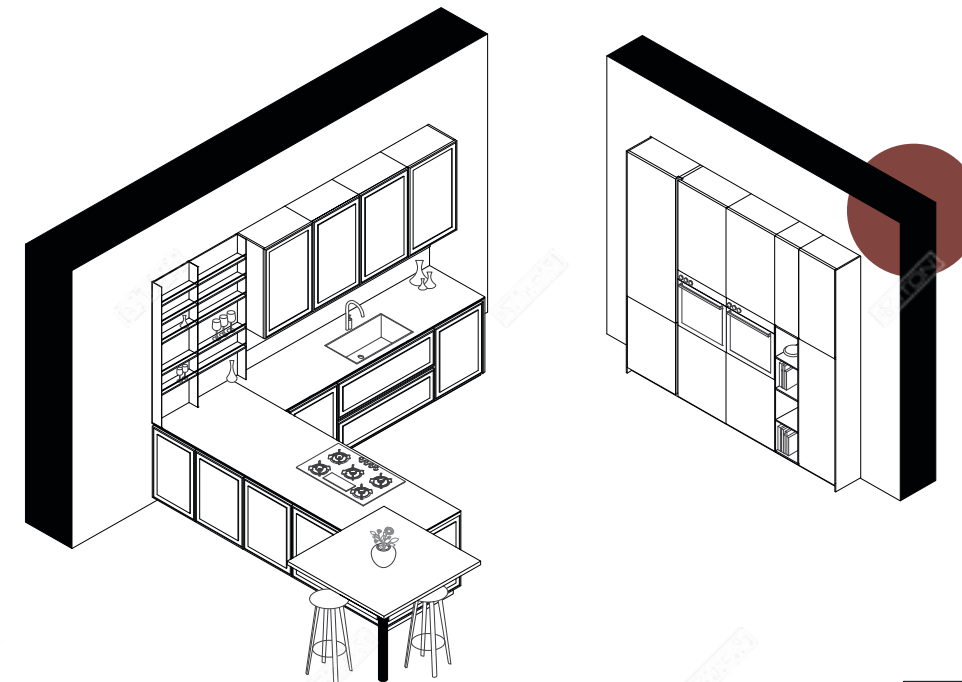

FACADE COLONNES\_ MÉNTA BILAMINE' BOIS NOCE MONZA  
 FACADE MEUBLES BAS\_ NEW MASA LAQUE GRIGIO BOX OPACO  
 FACADE VITRINE\_ NEW MASA AVEC CADRE LAQUE GRIGIO BOX OPACO, VERRE FUMÉ ET  
 ECLAIRAGE LED  
 PLAN DE TRAVAIL\_ GRES CALACATTA MICHELANGELO OPACO EP. 1,2 CM  
 PLAN SNACK\_ BILAMINE' BOIS NOCE MONZA  
 NEW GRID\_ DOS BILAMINE' BOIS NOCE MONZA AVEC MENSOLES IN PET LASER NERO  
 ONICE OPACO



# TALÌA

GRIGIO ANTRACITE OPACO / COTONE OPACO /  
NOCE AMERICANO

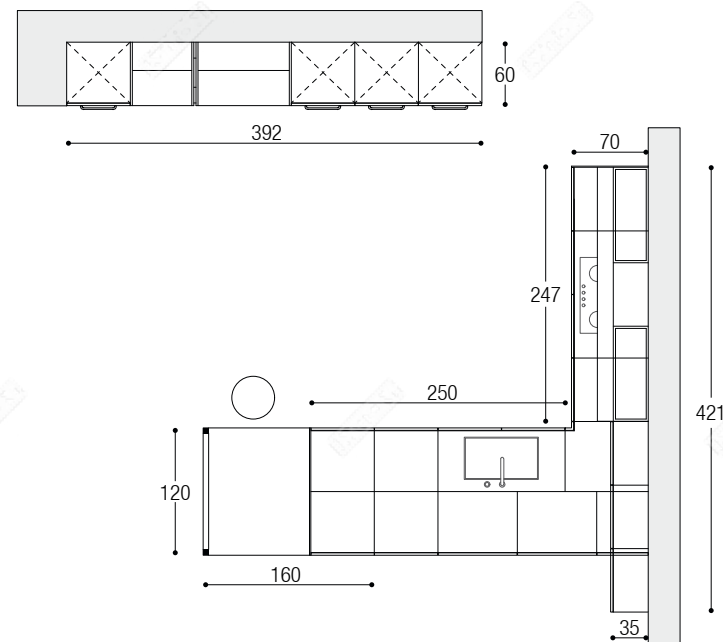
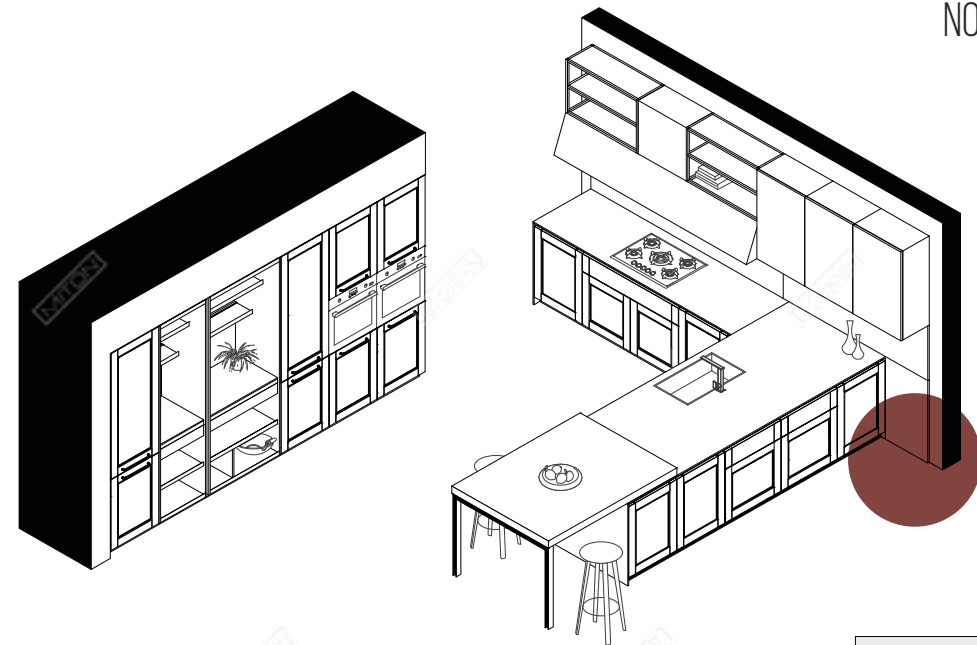

## MATERIALI

FACADE COLONNES\_ TALÌA LAQUE PORES OUVERTS COTONE OPACO  
FACADE MEUBLES BAS\_ TALÌA LAQUE PORES OUVERTS GRIGIO ANTRACITE OPACO  
FACADE MEUBLES HAUTS\_ MÈNTA BILAMINE' BOIS NOCE AMERICANO  
SYSTEME WAIND\_ STRUCTURE OUVERTE EN BILAMINE' BOIS NOCE AMERICANO AVEC  
DOS DE SERIE TISSU NOIR ET ECLAIRAGE LED  
PLAN DE TRAVAIL\_ GRES MARBLE GREY OPACO  
PLAN SNACK\_ BILAMINE' BOIS NOCE AMERICANO  
PIED\_ INDUSTRIAL NERO OPACO  
POIGNEE\_ TUBE NERO OPACO



**BILAMINATO OPACO / MATT BILAMINATE**



**MÉNTA**

**BILAMINATO CEMENTO / CONCRETE BILAMINATE**



**MÉNTA**

**BILAMINATO LEGNO / WOOD BILAMINATE**



**MÉNTA / MÉDEA**



**BILAMINATO PIETRA / STONE BILAMINATE**



**BILAMINATO 22 OPACO / 22 MATT BILAMINATE**



**BILAMINATO LEGNO / WOOD BILAMINATE**



**MÉNTA / WORKTOP**

**MÉNTA MÉDEA**

**MÉNTA MÉDEA**

**PET LASER / PET LASER**

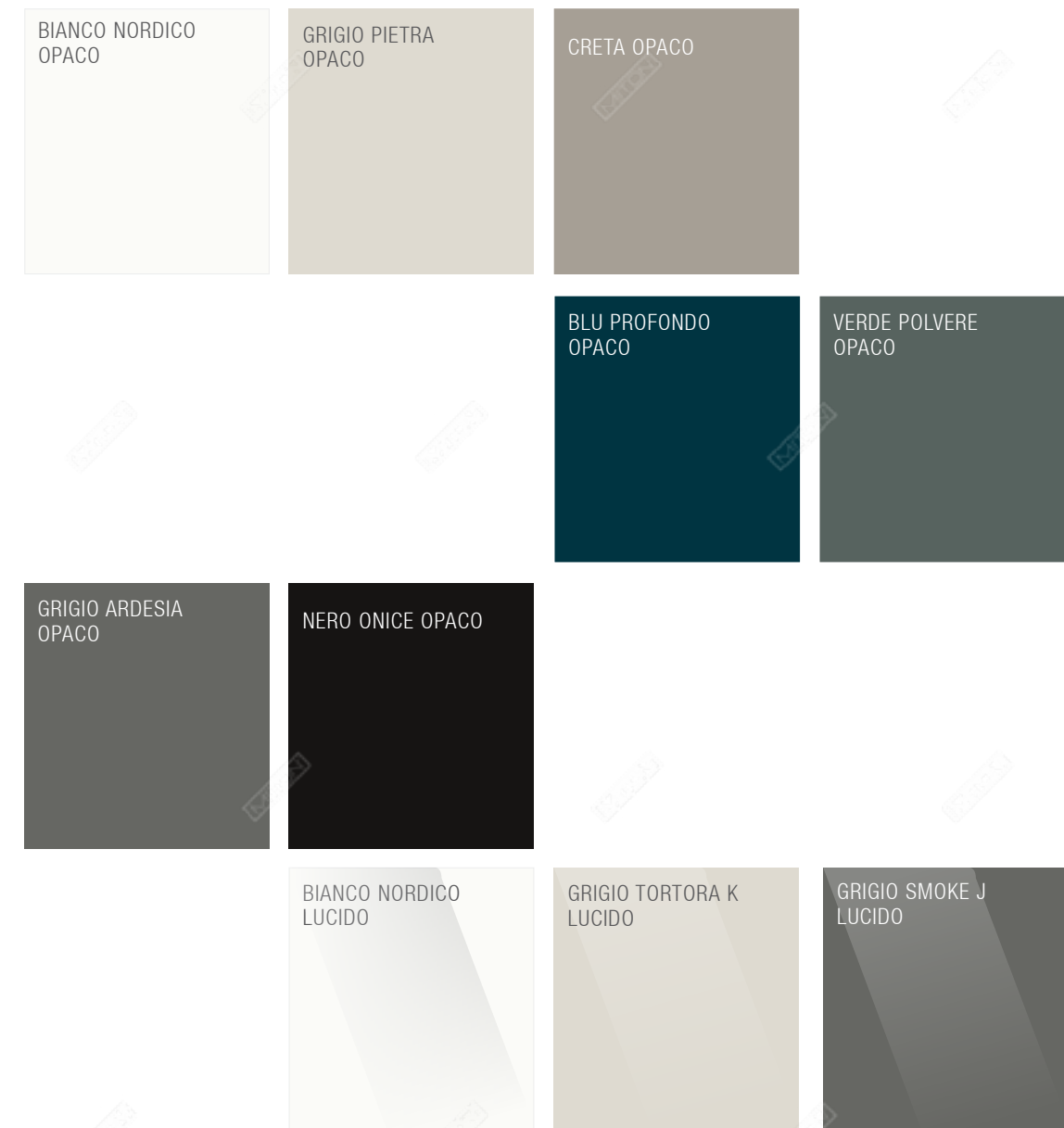

**MÉNTA**



**LACCATO OPACO / MATT LACQUERED**



**LACCATO OPACO / MATT LACQUERED**



**MÉNTA / ANUBA / NEW MASA**

**LACCATO OPACO / MATT LACQUERED**





**LAMINATO FENIX / FENIX LAMINATE**

**MÉNTA / WORKTOP**

**LAMINATO PIETRA / STONE LAMINATE**

**MÉNTA**

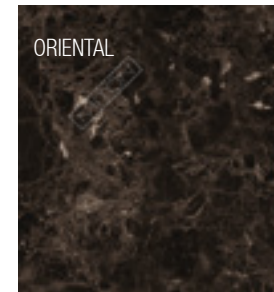
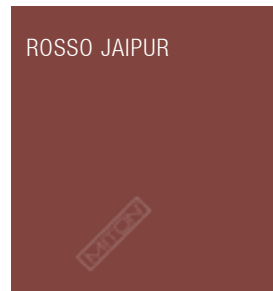
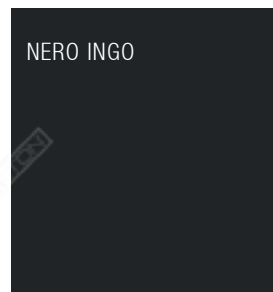
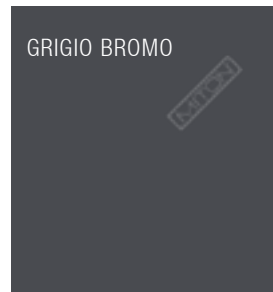
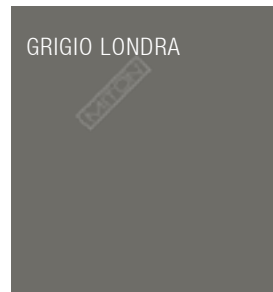
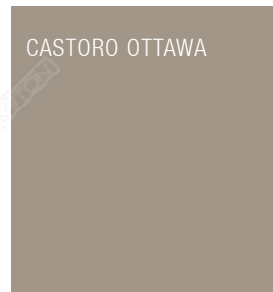
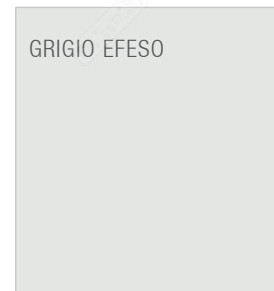
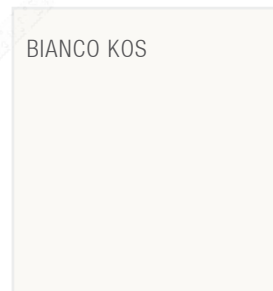

**MÉNTA MÉDEA**



**LACCATO LUCIDO / GLOSSY LACQUERED**

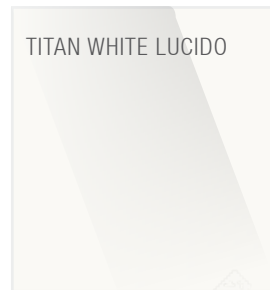

**LACCATO LUCIDO / GLOSSY LACQUERED**

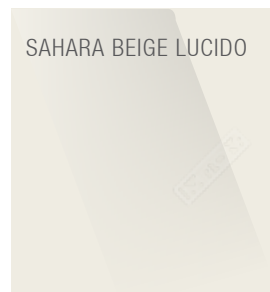
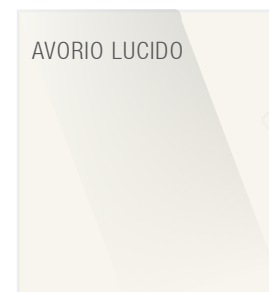
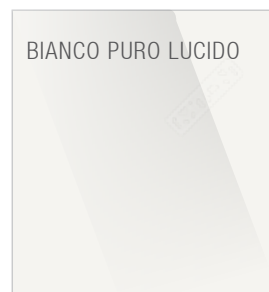

**LACCATO LUCIDO / GLOSSY LACQUERED**

**MÉNTA**

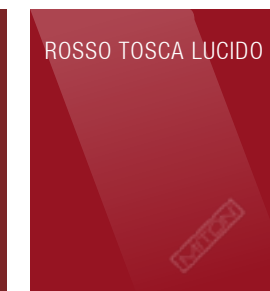
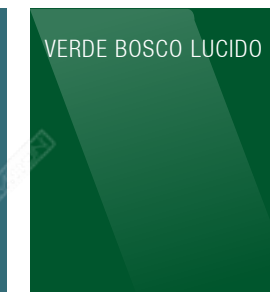



**LACCATO OPACO PORO APERTO / MATT LACQUERED OPEN PORE**

**TALIA**



**LEGNO IMPIALLACCIATO / WOOD VENEER**

**MÉNTA / TALIA**

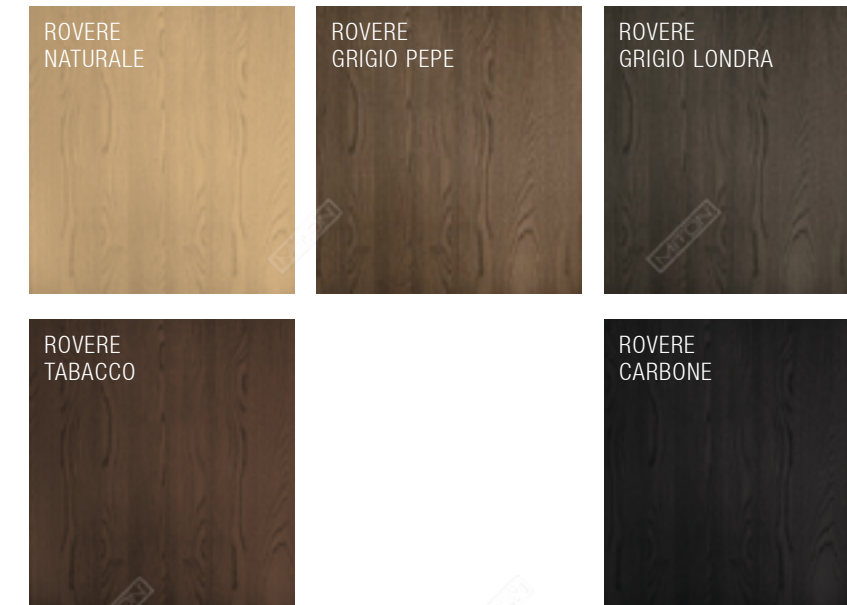

**LEGNO IMPIALLACCIATO SPECIALE / SPECIAL WOOD VENEER**

**MÉNTA**





LAMINATO HPL / LAMINATE

WORKTOP

LAMINATO HPL / LAMINATE

WORKTOP

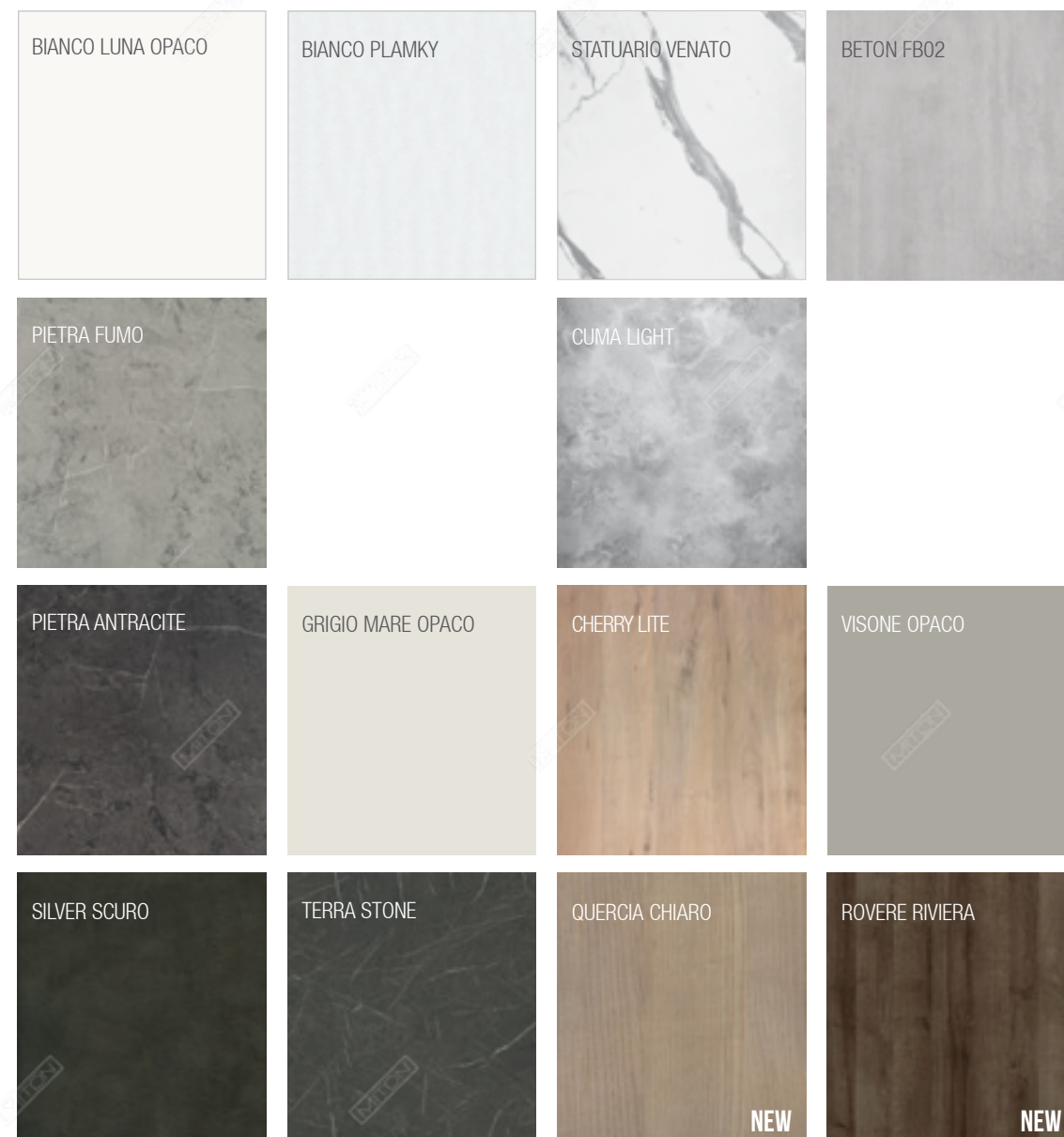



COMPACT H 1,2

WORKTOP

QUARZO SANTAMARGHERITA / QUARTZ

WORKTOP

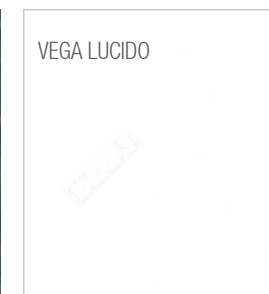
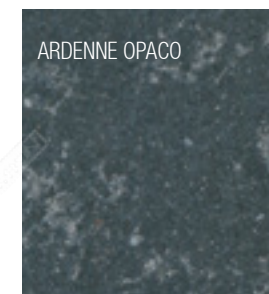
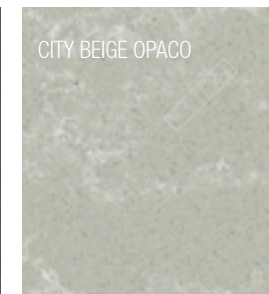
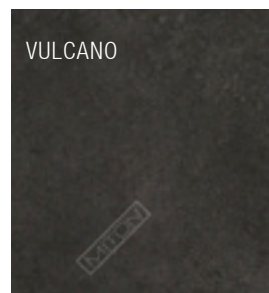
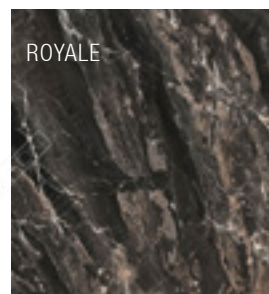
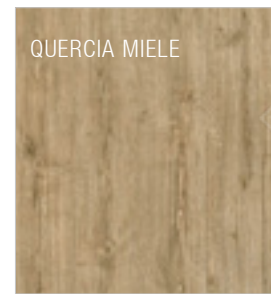
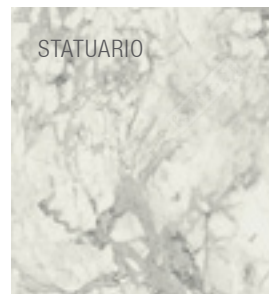
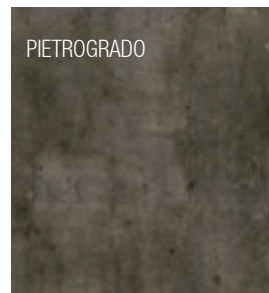
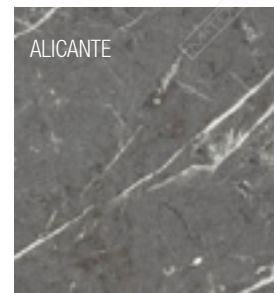



## TECHNO STONE SANTAMARGHERITA

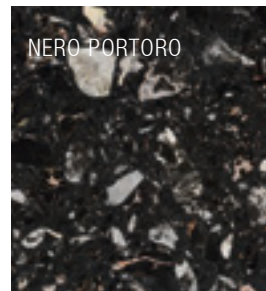
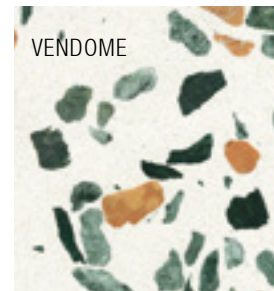
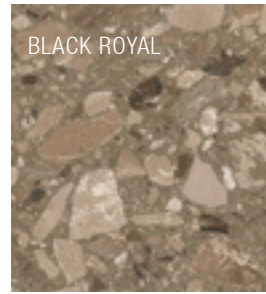

## WORKTOP

## GRES MARBLE LOOK LUCIDO



## WORKTOP

## GRES STONE OPACO

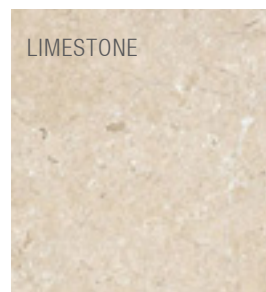
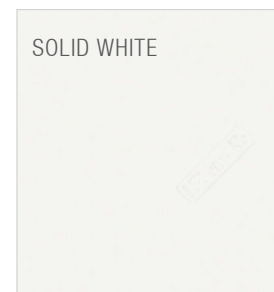

## GRES MARBLE LOOK OPACO

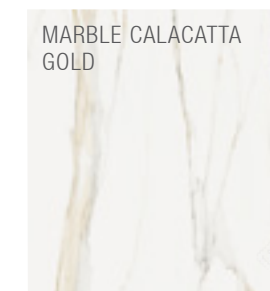
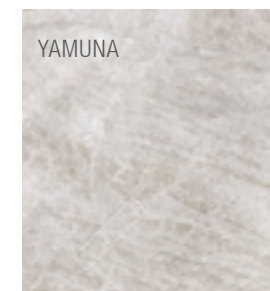
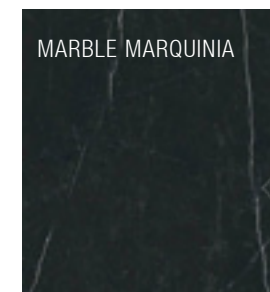



### GRES STONE LOOK OPACO

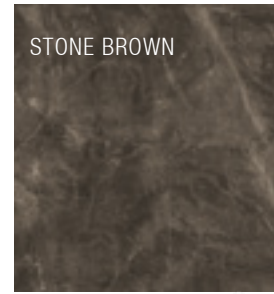

STONE BROWN



MARBLE GREY

### WORKTOP



EMPERADOR

### GRES LAMINAM OPACO



FOCOS SALE



FOCOS TERRA



FOCOS ROCCIA

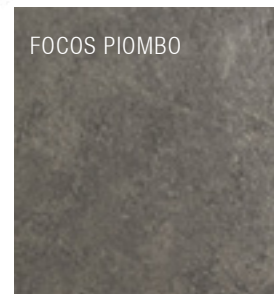

FOCOS PIOMBO



PIETRA DI SAVOIA GRIGIA



CALCE NERO



NERO GRECO

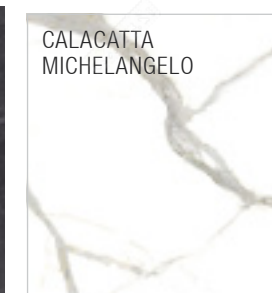

CALACATTA MICHELANGELO



PIETRA DI SAVOIA ANTRACITE

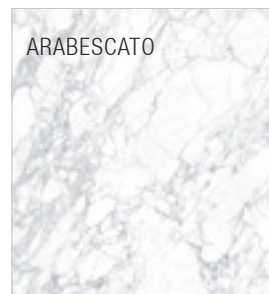

ARABESCATO

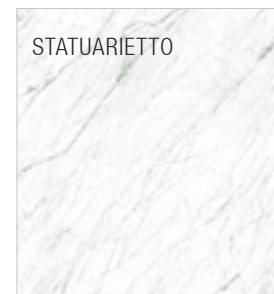

STATUARIETTO

### GRES LAMINAM OPACO



PIASENTINA GRIGIO FIAMMATO

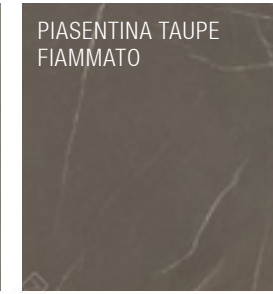

PIASENTINA TAUPE FIAMMATO

### WORKTOP



CARDOSO NERO FIAMMATO



PORFIDO MARRONE FIAMMATO

### PIETRE NATURALI / NATURAL STONES



BROWN ANTIQUE

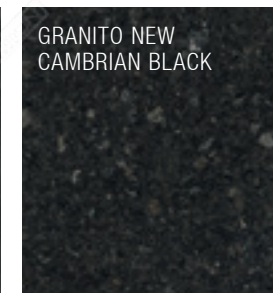

GRANITO NEW CAMBRIAN BLACK

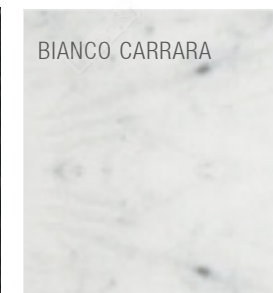

BIANCO CARRARA

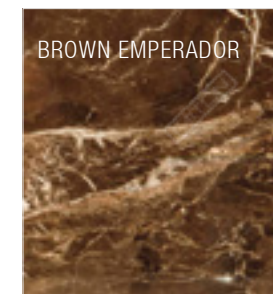

BROWN EMPERADOR



GREY STONE





ART DIRECTOR, RICERCA E SVILUPPO CUBO DESIGN  
PHOTOGRAPHY, MATIC ANIMATION  
COLOUR SEPARATION, MATIC ANIMATION  
GRAPHIC DESIGN, RICERCA E SVILUPPO CUBO DESIGN

RENDER, MATIC ANIMATION (MÉNTA - MÉDEA)  
RENDER, BIEFFE RENDERING (MÉNTA\_NOCE CORDESCO E VERDE POLVERE - ANUBA - TALÌA)

**CUBO DESIGN** S.R.L.

LOCALITÀ CASE SCIARRONI - GRASCIANO  
I-64024 NOTARESCO - TERAMO (TE) - ITALY  
INFO@CUBODESIGN.IT

CUBO DESIGN S.R.L. NEL PERSEGUIRE UNA POLITICA VOLTA AL COSTANTE MIGLIORAMENTO, SI RISERVA IL DIRITTO DI APPORTARE, IN QUALSIASI MOMENTO E SENZA PREAVVISO, LE MODIFICHE AI PRODOTTI CHE RITERRÀ UTILI E NECESSARIE / IN ORDER TO CONSTANTLY IMPROVE ITS PRODUCTS, CUBO DESIGN S.R.L. RESERVES THE RIGHT TO MODIFY ITS PRODUCTS AS IT SEES FIT, WITHOUT PRIOR NOTIFICATION.

L'EFFETTIVA DISPONIBILITÀ DI QUANTO A CATALOGO DEVE ESSERE EFFETTIVAMENTE VERIFICATA AL MOMENTO DELL'ORDINE / THE EFFECTIVE AVAILABILITY OF THE ARTICLES IN THE CATALOGUE, MUST BE ACTUALLY CHECKED OUT AT THE TIME OF THE ORDER.

A CAUSA DI NATURALI LIMITI TECNICI DI RIPRODUZIONE E STAMPA, IL COLORE DEI MODELLI A CATALOGO È PURAMENTE INDICATIVO E NON PUÒ COSTITUIRE MOTIVO DI RIVALSA / BECAUSE OF NATURAL TECHNICAL LIMITS OF THE METHOD OF REPRODUCTION AND PRINTING, THE COLOUR OF THE MODELS IN THE CATALOGUE IS PURELY INDICATIVE AND CANNOT BE CLAIMED AS REASON FOR COMPENSATION AND LEGAL ACTION.

CUBO DESIGN S.R.L. DECLINA OGNI RESPONSABILITÀ PER DIFETTI E MALFUNZIONAMENTI DI ELETTRODOMESTICI ED APPARECCHIATURE: EVENTUALI CONTESTAZIONI DOVRANNO ESSERE RIVOLTE DIRETTAMENTE AL PRODUTTORE ED AI LORO CENTRI DI ASSISTENZA / CUBO DESIGN S.R.L. EVERY LIABILITY FOR DEFECTS AND MALFUNCTIONING OF APPLIANCES AND PIECES OF EQUIPMENT: EVENTUAL CLAIMS WILL HAVE TO BE ADDRESSED DIRECTLY TO THE PRODUCERS AND THEIR ASSISTANCE CENTRES.